

Bergmann Dumper

3012 DSK_{PLUS}



Wheel dumper | cab
Three Way Tip



- High stability thanks to oscillating axle
- Swivelling operator's stand
- Electro hydraulic spring type cylinder park brake
- Compact dimensions and low weight

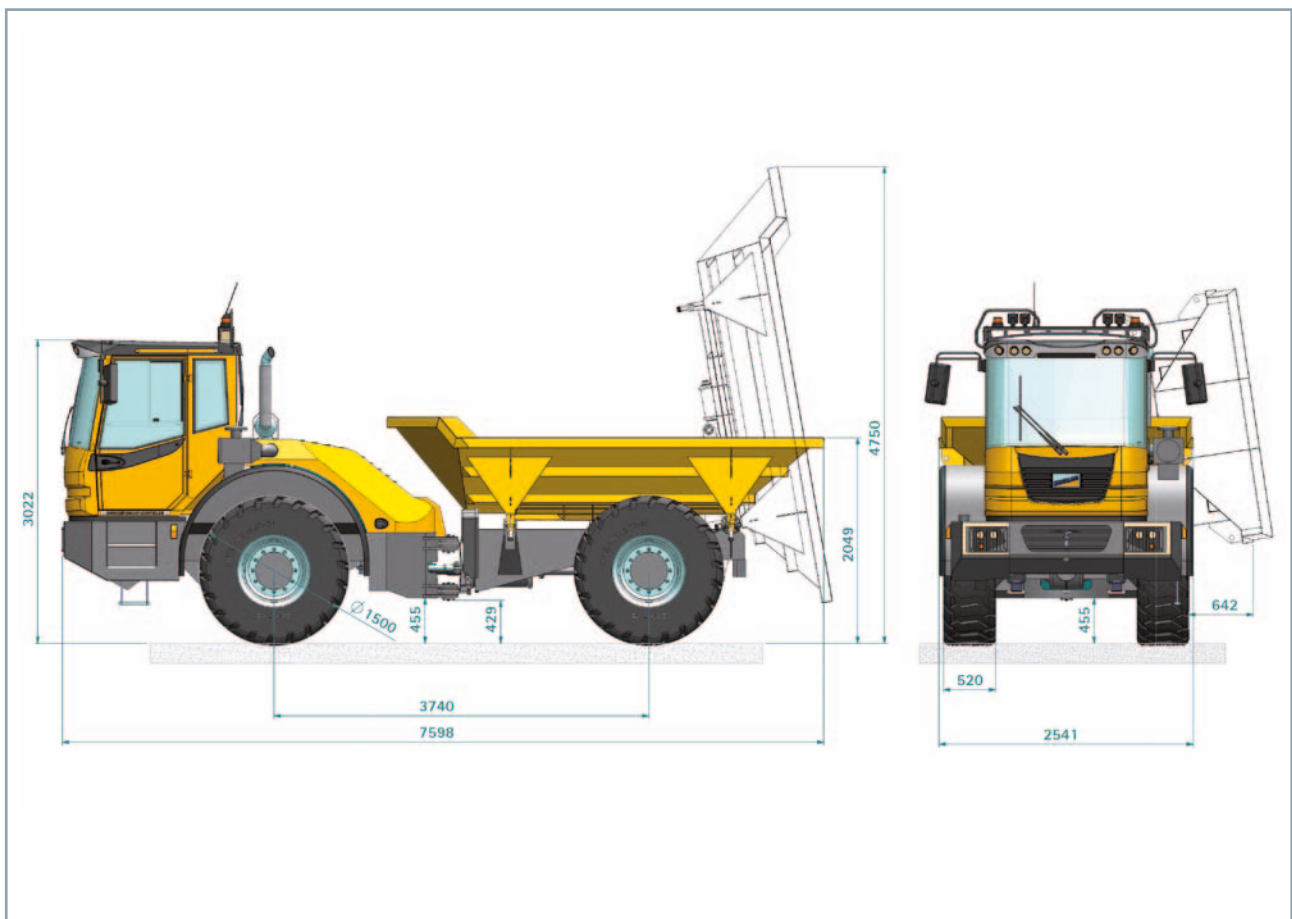

BERGMANN



Weight/Bucket Capacity

payload	12.000 kg
empty weight	10.020 kg
loading capacity struck	4,2 m ³
loading capacity heaped	8 m ³
bucket system	hydraulical 3-way-tipper, change of sides by simply changing the socket pins

Dimensions

clearance height	3.022 mm
tipping height	405 mm
loading height (front)	2.049 mm
total length	7.598 mm
total width	2.541 mm
ground clearance	429 mm

Transmission

load-dependent shift – shiftable by hand and automatically, self-adjusting optimisation of traction force and speed, speed control stepless forward and backwards, ZF-Ergo-Power transmission	
1. gear f/b	6/6 km/h
2. gear f/b	9/15 km/h
3. gear f/b	14/33 km/h
4. gear f	21 km/h
5. gear f	32 km/h
6. gear f	40 km/h

Steering

hydraulic articulated steering acting over priority valve
articulation: 37° left & right

Axles/Brakes

front axle hydraulically absorbed, rear axle fix, maintenance-free-oil-bath multi-disc brake in the wheel hubs with self-locking differential with a locking value of 45 %, hydraulically applied spring-type cylinder locking brake acting over articulated shaft on front and rear axle

Engine

4 cylinder Cummins diesel engine – water cooled –
power 119 kW with 2.200 rpm
stage IIIB/Tier IV Interim

Tires

standard 20.5-25 double coin

Bonnet

easy access to all maintenance and service points thanks to wide opening sectioned bonnet

Tank capacity

fuel	190 L
hydraulic oil	64 L

Electrics

24 V electric system with main switch, fault finding modus, fuel and hour counter, control lamps for engine oil; park brake, driving display, battery charging control, hydraulic filter, display for drive position

Standard Equipment

comfortable driver´s cab with air-suspended driver´s seat, swivelling operator´s stand, lighting system according to German traffic regulations, bucket from abrasion proof fine grain steel, flashing yellow light, cigarette lighter, roller blind for front windscreen, device for radio, loudspeaker and antenna, EC declaration of conformity